

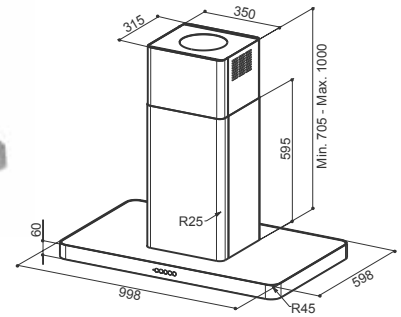

White matt



# T-LIGHT ISOLA

T-LIGHT ISOLA EV8P X A100 cod. 110.0456.264

T-LIGHT ISOLA EV8P WH MATT A100 cod. 110.0456.265

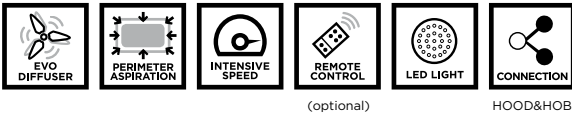

The hood is linked to the hob due to its controls integrated in the Faber hob

FEATURES	PERFORMANCES	ACCESSORIES
<b>Finish</b> · Stainless steel · White matt	<b>Speed</b> 1   2   3   INT <b>Air capacity IEC point</b> 260 380 525 635	<b>Cod. 112.0157.243</b> F9 Charcoal filter
<b>Controls</b> Squarcle touch	<b>Pressure</b> 390 500 510 530 <b>Input</b> 170 215 245 275	<b>Cod. 112.0157.354</b> Remote control
<b>Lighting</b> Perimeter LED light	<b>Noise level</b> 56 65 70 72	<b>Cod. 112.0185.276</b> FLL9 Charcoal filter Long Lasting
<b>Grease filter</b> Cassettes dishwasher safe		
<b>Ø of air outlet</b> 150 / 120 mm		
<b>Width</b> 1000 mm		
<b>Energy class</b> A		